

AS SHUTTLE NAILING MACHINE

ADS SHUTTLE NAILING MACHINE WITH DOUBLE JIGS

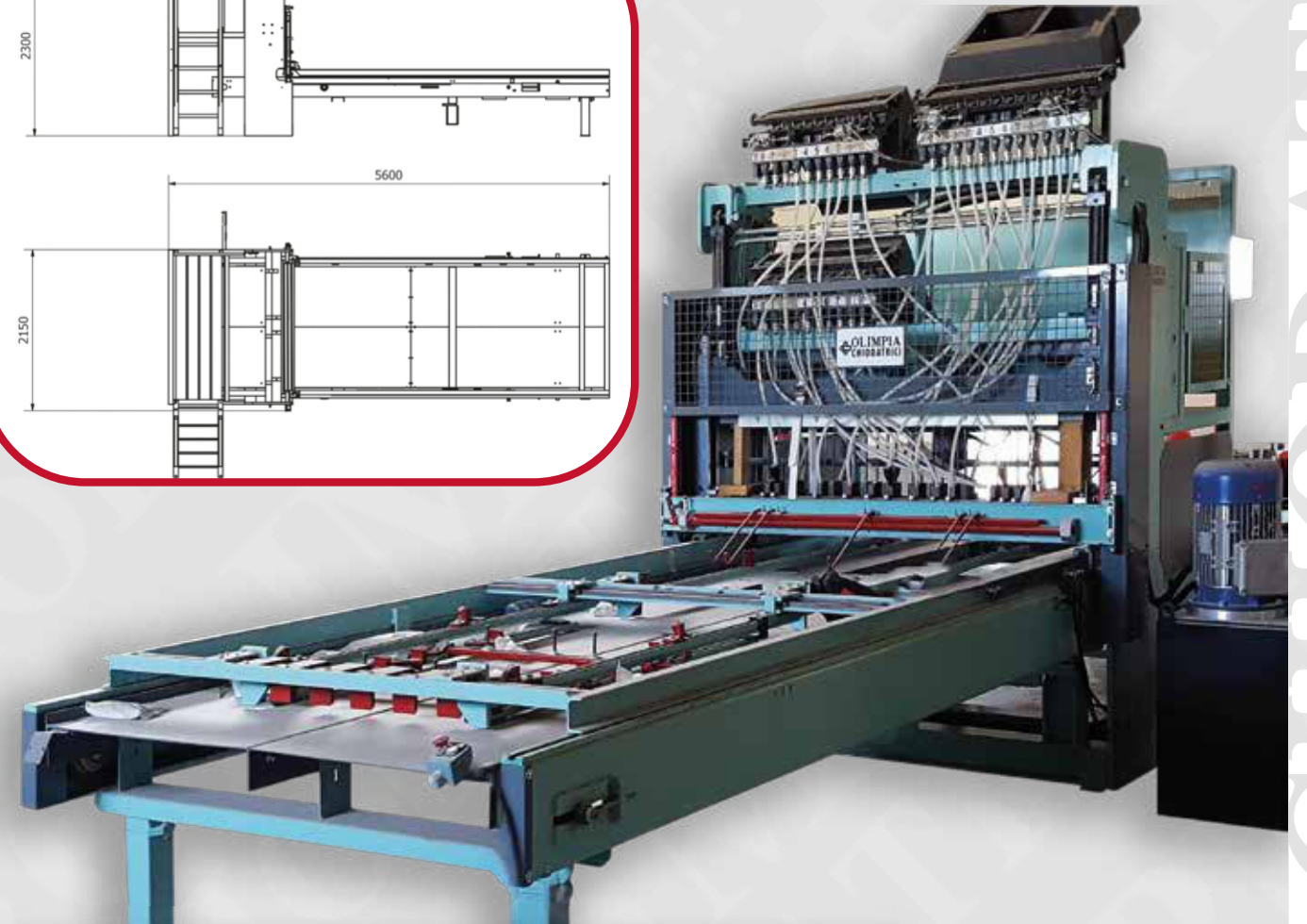
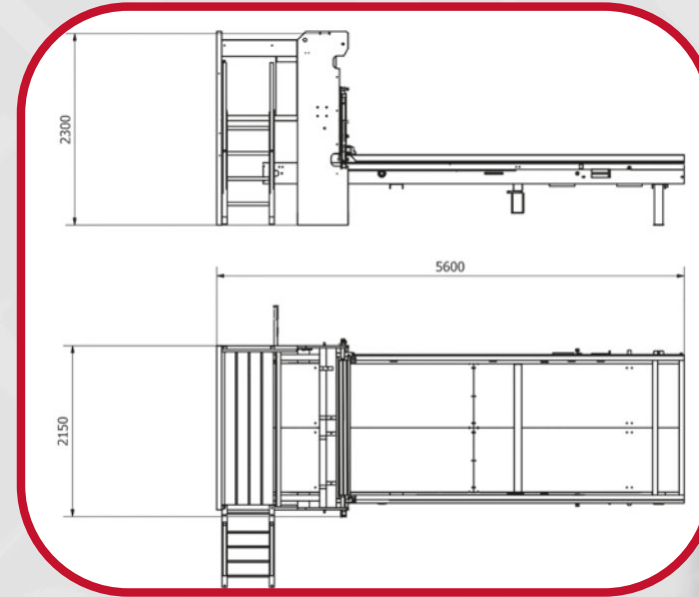
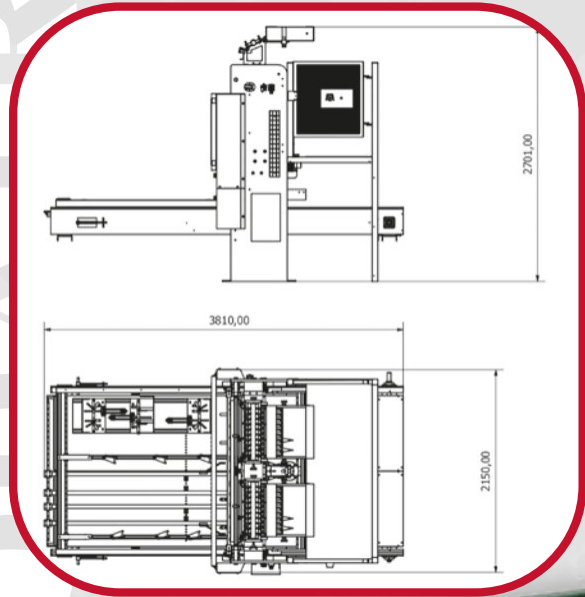

WORKERS	PRODUCTION in 1hour	NAILING CYCLE	CHANGE OVERTIMES
2/3	100 pieces approx	14" seconds	20" minutes

WORKERS	PRODUCTION in 1hour	NAILING CYCLE	CHANGE OVERTIMES
2/3	90 pieces approx	30" seconds	20" minutes

PCS 1	MACHINE DESCRIPTION
	AS - SHUTTLE NAILING MACHINE

PCS 1	MACHINE DESCRIPTION
	ADS - SHUTTLE NAILING MACHINE WITH DOUBLE JIGS

PCS	DESCRIPTION
11	N. 3 nails boxes with 10 drops each one
12	N. 27 hammers for nails from 27 mm to 90 mm
13	Autoregulated hydraulic system
14	Managed speed by the operator
15	Automatic controller for the nailing position
16	High efficiency hydraulic system
17	Touchscreen panel
18	N. 1 jigs on your drawing
19	Cooler for temperature higher than 45°C

PCS	DESCRIPTION
11	N. 3 nails boxes with 10 drops each one
12	N. 27 hammers for nails from 27 mm to 90 mm
13	Autoregulated hydraulic system
14	Managed speed by the operator
15	Automatic controller for the nailing position
16	High efficiency hydraulic system
17	Touchscreen panel
18	N. 1 jigs on your drawing
19	Cooler for temperature higher than 45°C

AS - SHUTTLE NAILING MACHINE

PALLET TYPES



PALLET DIMENSIONS (different sizes on request)

Width (W) ← → Length (L) ↑ ↓

TYPES AS	WxL 600x	WxL	WxL
AS 5 AAS	600 600 x	-	-
8 AAS 20	800 600 x	800 x 800	-
A	2000	800 x 2000	2000 x 2000

ADS - SHUTTLE NAILING MACHINE WITH DOUBLE JIGS

PALLET TYPES



PALLET DIMENSIONS (different sizes on request)

Width (W) ← → Length (L) ↑ ↓

TYPES ADS	WxL 600x	WxL	WxL
ADS 5 A	600 600 x	-	-
ADS 8 A	800 600 x	800 x 800	-
ADS 20 A	2000	800 x 2000	2000 x 2000